

NU-JB395

NU-JB Series

395 W

The Project Solution

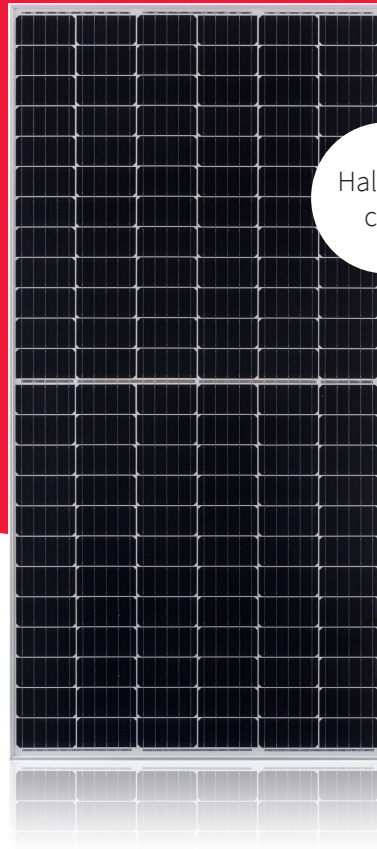

Half-cut cell

Powerful product features



Max. system voltage 1,500 V
Lower BOS costs by longer strings



0/+5%

Guaranteed positive power tolerance (0/+5%)



IN
OUT

PERC monocrystalline silicon photovoltaic modules
High module efficiency 19.6%



Tested and certified
VDE, IEC/EN61215, IEC/EN61730
Safety class II, CE
Fire rating class C
MCS accredited product



Half-cut cell
Improved shading performance
Lower internal losses
Reduced hot spot risk



5 busbar technology
Improved reliability
Higher efficiency
Reduced series resistance



Robust product design
PID resistance test passed
Salt mist test passed (IEC61701)
Ammonia test passed (IEC62716)
Dust and sand test passed (IEC60068)

Your solar partner for life



60 years of solar expertise



Linear power output guarantee



Local support team in Europe



Product guarantee



50 million PV modules installed



Top PV brand award



Energy Solutions

SHARP
Be Original.

Electrical data (STC)

NU-JB395

Maximum power	P_{max}	395	W_p
Open-circuit voltage	V_{oc}	49.45	V
Short-circuit current	I_{sc}	10.35	A
Voltage at point of maximum power	V_{mpp}	41.07	V
Current at point of maximum power	I_{mpp}	9.62	A
Module efficiency	η_m	19.6	%

STC = Standard Test Conditions: irradiance 1,000 W/m², AM 1.5, cell temperature 25 °C.

Rated electrical characteristics are within ±10% of the indicated values of I_{sc} , V_{oc} and 0 to +5% of P_{max} (power measurement tolerance ±3%).

Electrical data (NMOT)

NU-JB395

Maximum power	P_{max}	293.8	W_p
Open-circuit voltage	V_{oc}	46.87	V
Short-circuit current	I_{sc}	8.39	A
Voltage at point of maximum power	V_{mpp}	38.11	V
Current at point of maximum power	I_{mpp}	7.71	A

NMOT = Nominal Module Operating Temperature: 45 °C, irradiance 800 W/m², air temperature of 20 °C, wind speed of 1 m/s.

Mechanical data

Length	2,008 mm
Width	1,002 mm
Depth	40 mm
Weight	23.5 kg

Temperature coefficient

P_{max}	-0.353%/°C
V_{oc}	-0.269%/°C
I_{sc}	0.037%/°C

Limit values

Maximum system voltage	1,500 V DC
Over-current protection	20 A
Temperature range	-40 to 85 °C
Max. mechanical load (snow/wind)	2,400 Pa
Tested snow load (IEC61215 test pass*)	5,400 Pa

Packaging data

Modules per pallet	26 pcs
Pallet size (L × W × H)	2.08 m × 1.12 m × 1.19 m
Pallet weight	Approx. 650 kg

Dimensions (mm)

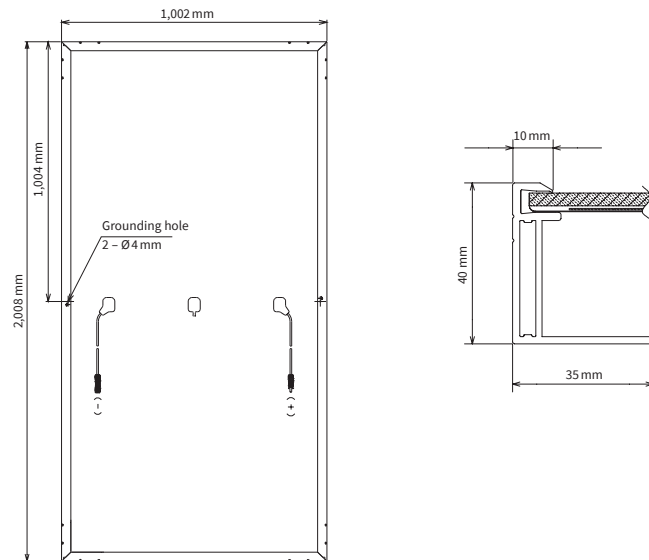

*Please refer to SHARP's installation manual for details.

General data

Cells	Half-cut cell mono, 159 mm × 79.5 mm, 2 strings of 72 cells in series
Front glass	Anti-reflective high transmissive low iron tempered glass, 3.2 mm
Frame	Anodized aluminium alloy, silver
Backsheet	White
Connection box	IP68 rating, 3 bypass diodes
Cable	∅ 4.0 mm ² , length 1,400 mm [or on request (+) 300 mm, (-) 100 mm]
Connector	C1, IP68

Note: Technical data is subject to change without prior notice. Before using SHARP products, please request the latest data sheets from SHARP. SHARP accepts no responsibility for damage to devices which have been equipped with SHARP products on the basis of unverified information. The specifications may deviate slightly and are not guaranteed. Installation and operating instructions are to be found in the corresponding handbooks, or can be downloaded from www.sharp.eu. This module should not be directly connected to a load.